



FEATURES

- 8 digit LCD with backlight display
- User programmable CT primary, CT Secondary, PT primary & PT Secondary
- User programmable network selection
- Memory retention
- Password protected energy reset
- Potential free Pulse output for energy
- 90 to 270V AC/DC auxiliary supply
- Battery backup (optional)
- RS485 communication (MODBUS Protocol)

SPECIFICATIONS

DISPLAY

8 digit LCD display. Height 10.5mm

LCD INDICATIONS

- INT** - Integration of energy
- X10** - Resolution is 10
- REV** - Reverse connected CT or Voltage wiring
- ↔** - Communication in progress
- ⚡** - Pulse output
- BAT** - Battery backed display

WIRING INPUT

3 Ø - 4 wire, 3 Ø - 3 wire, 2 Ø - 3 wire, & 1 Ø - 2 wire system

RATED INPUT VOLTAGE

11 to 300V AC (L-N) ; 19 to 519V AC (L-L)

FREQUENCY RANGE

50/60 Hz

RATED INPUT CURRENT

Nominal 5A (Min-11mA, Max-6A)

CT PRIMARY

1A / 5A to 10,000A (Programmable for any Value)

Note: 1A to 10,000A if CT secondary is 1 else CT primary is 5A to 10,000A

CT SECONDARY

1A or 5A (programmable)

PT PRIMARY

100V to 500kV (Programmable for any value)

PT SECONDARY

100 to 500V AC (L-L)
(Programmable for any value)

BURDEN

0.5 VA@5A per phase

MEASUREMENT

- Total active Energy (kWh)
- Total reactive Energy (kVArh)
- Total apparent Energy (kVAh)
- Total active power (kW)
- Total reactive power (kVAr)
- Power factor (Individual & Average)

Note: All energies are resettable

ACCURACY

- Class 1 for Active/Apparent energy
- Class 2 for Reactive energy
- Class 0.5 for Power

RESOLUTION

| PT Ratio x CT Ratio | kWh | Pulse |
|---------------------|-------|-------|
| <15 | 0.01K | 0.01K |
| <150 | 0.1K | 0.1K |
| <1500 | 1K | 1K |
| <15000 | 0.01M | 0.01M |
| <150000 | 0.1M | 0.1M |
| <1500000 | 1M | 1M |
| ≥1500000 | 10M | 10M |

NOTE:

- 1) For power, resolution is automatically adjusted
- 2) For power factor, resolution is 0.01
- 3) INT blinks after every 5 seconds, if load on any one of three phase is present

AUXILIARY SUPPLY RANGE

90 to 270V AC/DC, 50/60Hz

OUTPUT

- Pulse Output:** Voltage range - 24V DC
Current capacity - 100 mA max
- Pulse Width:** 100 ms ± 50 ms.

SERIAL COMMUNICATION

Interface standard & protocol
RS485 & MODBUS RTU

Communication address

1 to 255

Transmission mode

Half duplex

Data types

Float and Integer

Transmission distance

500 m maximum

Transmission speed

300, 600, 1200, 2400, 4800, 9600, 19200
(in bps)

Parity

None, Odd, Even

Stop bits

1 or 2

Response time

100 ms (independent of baud rate)

TEMPERATURE

Operating: 0 to 50 °C
Storage: -20 to 75 °C

HUMIDITY

85% non-condensing

MOUNTING

Panel mounting

WEIGHT

310 gms

SAFETY PRECAUTIONS

All safety related codifications, symbols and instructions that appear in this operating manual or on the equipment must be strictly followed to ensure the safety of the operating personnel as well as the instrument.

If the equipment is not handled in a manner specified by the manufacturer it might impair the protection provided by the equipment.

CAUTION: Read complete instructions prior to installation and operation of the unit.

CAUTION: Risk of electric shock.

WIRING GUIDELINES

WARNING:

1. To prevent the risk of electric shock power supply to the equipment must be kept OFF while doing the wiring arrangement.
2. Wiring shall be done strictly according to the terminal layout. Confirm that all connections are correct.
3. Use lugged terminals.
4. To eliminate electromagnetic interference use of wires with adequate ratings and twists of the same in equal size shall be made.
5. Cable used for connection to power source, must have a cross section of 1.5mm². These wires shall have current carrying capacity of 6A.

MAINTENANCE

1. The equipment should be cleaned regularly to avoid blockage of ventilating parts.
2. Clean the equipment with a clean soft cloth . Do not use Isopropyl alcohol or any other cleaning agent.

INSTALLATION GUIDELINES

CAUTION:

1. This equipment, being built-in-type, normally becomes a part of main control panel and in such case the terminals do not remain accessible to the end user after installation and internal wiring.
2. Conductors must not come in contact with the internal circuitry of the equipment or else it may lead to a safety hazard that may in turn endanger life or cause electrical shock to the operator.
3. Circuit breaker or mains switch must be installed between power source and supply terminals to facilitate power 'ON' or 'OFF' function. However this switch or breaker must be installed in a convenient position normally accessible to the operator.
4. Before disconnecting the secondary of the external current transformer from the equipment, make sure that the current transformer is short circuited to avoid risk of electrical shock and injury.

CAUTION:

1. The equipment shall not be installed in environmental conditions other than those mentioned in this manual.
2. The equipment does not have a built-in-type fuse. Installation of external fuse of rating 275VAC/1Amp for electrical circuitry is highly recommended.

MECHANICAL INSTALLATION

For installing the meter

1. Prepare the panel cutout with proper dimensions as shown below :

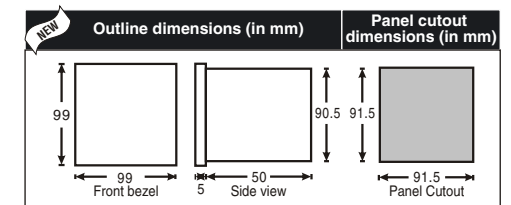

2. Push the meter into the panel cutout. Secure the meter in its place by pushing the clamp on the rear side. The clamps must be secured in diagonally opposite slots.

3. For proper sealing, tighten the screws evenly with required torque.

CAUTION:

The equipment in its installed state must not come in close proximity to any heating sources, caustic vapors, oils, steam, or other unwanted process by-products.

EMC Guidelines:

1. Use proper input power cables with shortest connections and twisted type.
2. Layout of connecting cables shall be away from any internal EMI source.

TERMINAL CONNECTIONS

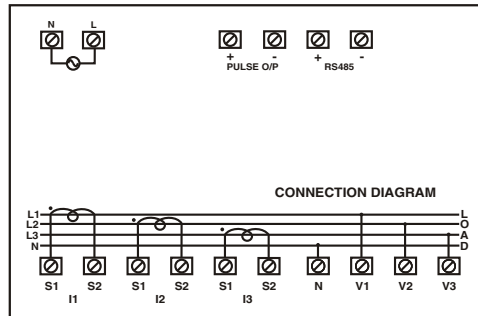

FRONT PANEL DESCRIPTION

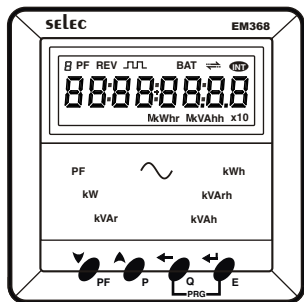

Keys Description (Online pages)

| Sr No | Keys | Function |
|-------|--------|---|
| 1 | PF (▼) | To view individual and average power factor |
| 2 | P (▲) | To view total active power |
| 3 | Q (←) | To view total reactive power |
| 4 | E (↵) | To view total reactive & apparent energy |

NOTE:

By default total active energy (kWh) will be displayed all the time and at momentary key press unit shall display the corresponding page for 5 sec.

Keys Description (Configuration)

| Sr No | Functions | Key press |
|-------|---|--------------------------|
| 1 | To enter into configuration mode. | ← & ↵ for 3 seconds |
| 2 | To scroll through the pages in forward direction in configuration mode. | ↵ go to next page |
| 3 | To scroll through the pages in reverse direction in configuration mode. | ← go to previous page |
| 4 | To increase and decrease all parameter values | ▲ Increase ▼ Decrease |

CONFIGURATION SCHEME (parameter setting)

To enter configuration: Press ← & ↵ for 3 sec

| Key press | Display | Description |
|---|-------------------------------|-------------------------------------|
| 1. Password Factory setting: 10 | | |
| | Display <code>PA55Y0P0</code> | |
| Press ▼/▲ | <code>10</code> | Range: 0 to 9998 |
| | | Press ← key for next parameter |
| 2. Change password Factory setting: No | | |
| | Display <code>CN6PASyD</code> | |
| Press ▼/▲ | <code>NO</code> | Range: No / Yes |
| | | Press ← for next parameter |
| Note: If 'NO' then after pressing ← key, menu will go to network selection | | |
| 3. New password Factory setting: 0 | | |
| | Display <code>NEyPASyD</code> | |
| Press ▼/▲ | <code>0</code> | Range: 0 to 9998 |
| | | Press ← for next parameter |
| | | Press ← for previous parameter |
| 4. Network selection Factory setting: 3P - 4W | | |
| | Display <code>NYSEL</code> | |
| Press ▼/▲ | <code>3P-4W</code> | Range: 3 Ø - 4 wire 3 Ø - 3 wire |
| | | Press ← for next parameter |
| Note: For 2 Ø 3 wire, 1 Ø 2 wire select 3 Ø 4 wire network | | |

| Key press | Display | Description |
|--|-------------------------------|-------------------------------------|
| 5. CT secondary Factory setting: 5 | | |
| | Display <code>CT SEC</code> | |
| Press ▼/▲ | <code>5</code> | Range: 1A or 5A |
| | | Press ← for next parameter |
| | | Press ← for previous parameter |
| 6. CT primary Factory setting: 5 | | |
| | Display <code>CT PPIn</code> | |
| Press ▼/▲ | <code>5</code> | Range: 5 to 10,000A OR 1 to 10,000A |
| | | Press ← for next parameter |
| | | Press ← for previous parameter |
| Note: 1 to 10,000A if CT secondary is 1 else CT primary is 5 to 10,000A | | |
| 7. PT secondary Factory setting: 350 | | |
| | Display <code>PT SEC</code> | |
| Press ▼/▲ | <code>350</code> | Range: 100 to 500V AC (L-L) |
| | | Press ← for next parameter |
| | | Press ← for previous parameter |
| 8. PT primary Factory setting: 350 | | |
| | Display <code>PT PPIn</code> | |
| Press ▼/▲ | <code>350</code> | Range: 100V to 500kV |
| | | Press ← for next parameters |
| | | Press ← for previous parameter |
| 9. Battery backup Factory setting: No | | |
| | Display <code>BAtEeBUP</code> | |
| Press ▼/▲ | <code>NO</code> | Range: No / Yes |
| | | Press ← for next parameter |
| | | Press ← for previous parameter |
| 10. Slave ID Factory setting: 1 | | |
| | Display <code>SLAVE ID</code> | |
| Press ▼/▲ | <code>1</code> | Range: 1 to 255 |
| | | Press ← for next parameter |
| | | Press ← for previous parameter |
| (Optional, available in EM368-C) | | |

| Key press | Display | Description |
|---|---------------------------------|---|
| 11. Baud rate Factory setting: 9600 | | |
| | Display <code>bd RATE</code> | |
| Press ▼/▲ | <code>9600</code> | Range: 300, 600, 1200, 2400, 4800, 9600 & 19200 |
| | | Press ← for next parameter |
| | | Press ← for previous parameter |
| (Optional, available in EM368-C) | | |
| 12. Parity Factory setting: None | | |
| | Display <code>PARITY</code> | |
| Press ▼/▲ | <code>NONE</code> | Range: Even, Odd, None |
| | | Press ← for next parameter |
| | | Press ← for previous parameter |
| (Optional, available in EM368-C) | | |
| 13. Stop bit Factory setting: 1 | | |
| | Display <code>STOPbit</code> | |
| Press ▼/▲ | <code>1</code> | Range: 1 / 2 |
| | | Press ← for next parameter |
| | | Press ← for previous parameter |
| (Optional, available in EM368-C) | | |
| 14. Reset energy Factory setting: No | | |
| | Display <code>RESET ENRG</code> | |
| Press ▼/▲ | <code>NO</code> | Range: No / Yes |
| | | Press ← for next parameter |
| | | Press ← for previous parameter |
| Note: If 'NO' then after pressing ← key, menu will go to Network selection | | |
| 15. Password Factory setting: 11 | | |
| | Display <code>PA55Y0P0</code> | |
| Press ▼/▲ | <code>11</code> | Range: 1 to 9999 |
| | | Press ← for next parameter |
| | | Press ← for previous parameter |
| Note: Password is : configuration password + 1 | | |
| 16. Reset Active Energy Factory setting: No | | |
| | Display <code>RESET EWh</code> | |
| Press ▼/▲ | <code>NO</code> | Range: No / Yes |
| | | Press ← for next parameter |
| | | Press ← for previous parameter |
| Note: User should note the reading before resetting | | |

| Key press | Display | Description |
|---|----------|--|
| 17. Reset Apparent Energy Factory setting: No | | |
| Display | 05E 21A8 | |
| Press | 00 | Range: No / Yes |
| ▼/▲ | | Press ◀ for next parameter Press ▶ for previous parameter |
| Note: User should note the reading before resetting | | |
| 18. Reset Reactive Energy Factory setting: No | | |
| Display | 05E 21A8 | |
| Press | 00 | Range: No / Yes |
| ▼/▲ | | Press ◀ for next parameter Press ▶ for previous parameter |
| Note: User should note the reading before resetting | | |
| 19. Default value Factory setting: No | | |
| Display | DEFAULT | |
| Press | 00 | Range: No / Yes |
| ▼/▲ | | Press ◀ for next parameter Press ▶ for previous parameter |
| Note: On pressing ◀ key, configuration will go to network selection page. If 'yes' selected unit will be formatted to factory setting | | |

- Exit configuration mode:**
- Press ◀ & ◀ key for 3 sec in configuration mode
 - Do not press any key for 30 sec in configuration mode.
 - Power OFF and power ON the unit again.

- Note:-**
- 1) Pressing ◀ key will save the value of the current parameter and move on to next parameter.
 - 2) Continuous operating of ▼ or ▲ key makes parameter value update speed faster in 3 stages after 7 seconds
 - 3) In configuration menu repeated pressing of ◀ key will allow toggling between all the configuration parameters

USER GUIDE

What does the INT, REV, X10, COM & BAT on the LCD display indicate?

- **INT:** The INT on the LCD provides quick visual indication of energy integration. INT indication keeps blinking once in 5 sec, for presence of voltage & current in any of the three phases.

- **X10:** X10 on the LCD is ON when the resolution is 10. It is the indication of count reading which must be multiplied by 10 to get actual kWh / kVAh / kVAh consumed.
- **REV:** REV on the LCD gives the indication of reversal of one or more CT connections / Phase. In such cases meter may not indicate the correct energy consumption. The CT should be connected to the meter with correct polarities.
- This symbol on the LCD shows that the communication is in progress.
- **BAT:** BAT on the LCD shows that the unit is working on battery in absence of auxiliary supply. **The display will turn OFF after 48 hrs when operated in battery backup mode continuously. No measurement or output will take place in this mode.**
- This symbol on the LCD indicates that a pulse output is available.

TYPICAL WIRING DIAGRAM

3 PHASE 4-WIRE (COMMONLY USED) WIRING DIAGRAM

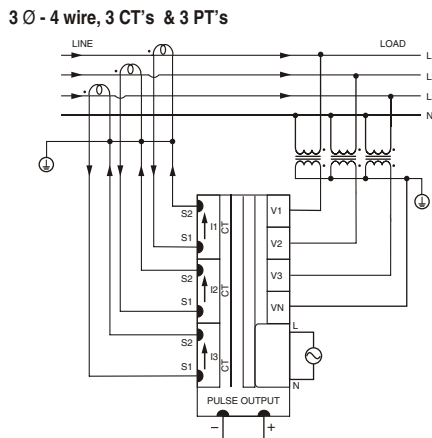
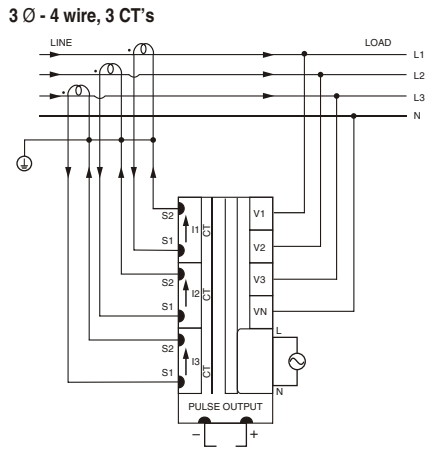

3 PHASE 3-WIRE WIRING DIAGRAM

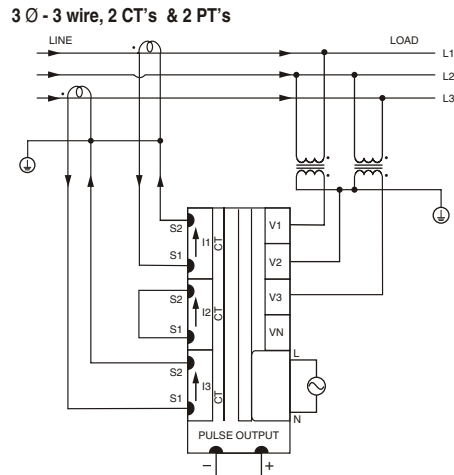
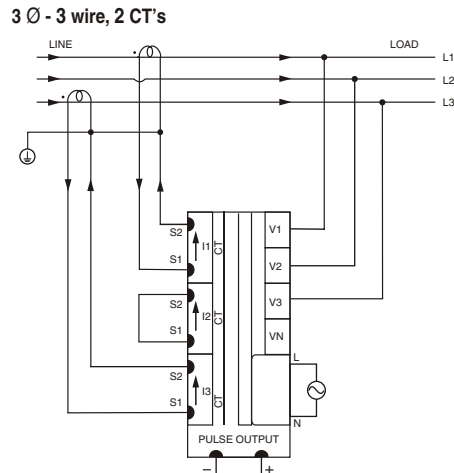

2 PHASE 3-WIRE WIRING DIAGRAM

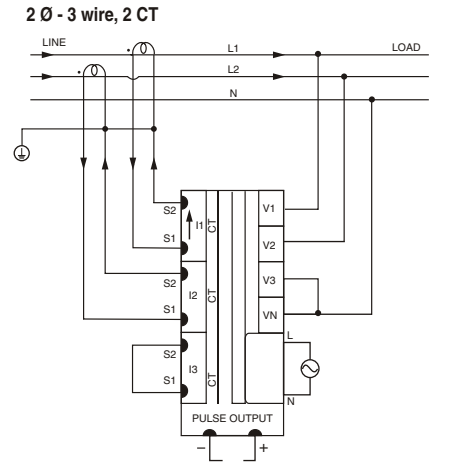

2 Ø - 3 wire, 2 CT's & 2 PT's

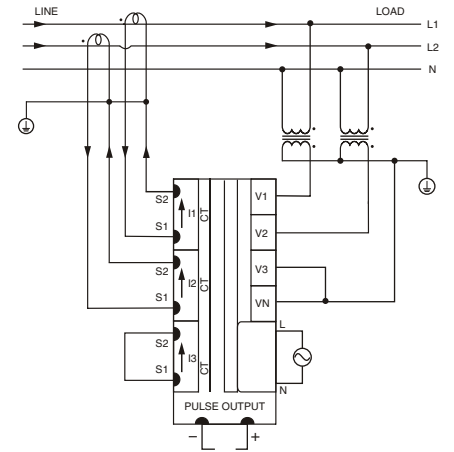

1 PHASE 2-WIRE (COMMONLY USED) WIRING DIAGRAM

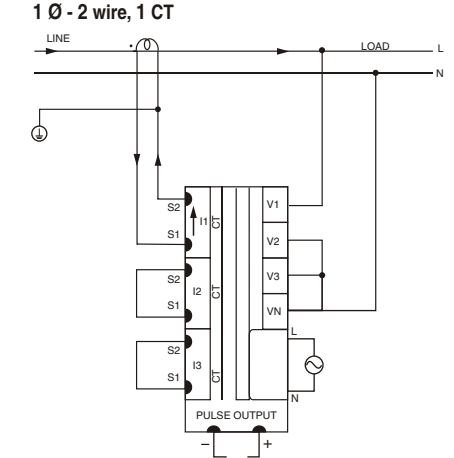

CONNECTION DIAGRAM FOR COMMUNICATION

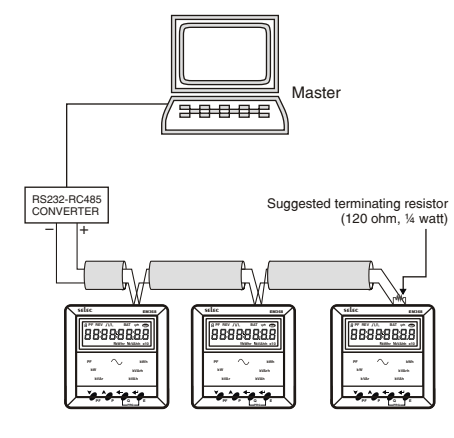

| MODBUS register addresses list | | | | | | |
|---|-------------|----------------------|-------------------|-----------------------|-------------------|----------------|
| Readable parameters from EM368 | | | | | | |
| Address | Hex Address | Parameter | Length (Register) | Data Structure | | |
| 30000 | 0x00 | Active Energy | 2 | Float | | |
| 30002 | 0x02 | Apparent Energy | 2 | Float | | |
| 30004 | 0x04 | Reactive Energy | 2 | Float | | |
| 30006 | 0x06 | Power Factor Phase 1 | 2 | Float | | |
| 30008 | 0x08 | Power Factor Phase 2 | 2 | Float | | |
| 30010 | 0x0A | Power Factor Phase 3 | 2 | Float | | |
| 30012 | 0x0C | Average Power factor | 2 | Float | | |
| 30014 | 0x0E | Total kW | 2 | Float | | |
| 30016 | 0x10 | Total kVAh | 2 | Float | | |
| Readable / Writable parameters from EM368 | | | | | | |
| Address | Hex Address | Parameter | Range | | Length (Register) | Data Structure |
| | | | Min value | Max value | | |
| 40000 | 0x00 | New Password | 1 | 9998 | 1 | Integer |
| 40001 | 0x01 | N/W selection | Value | Meaning | | |
| | | | 0 | 3P-4W | 1 | Integer |
| | | | 1 | 3P-3W | | |
| 40002 | 0x02 | CT Secondary | Write Value | CT Secondary | 1 | Integer |
| | | | 1 | 1A | | |
| | | | 5 | 5A | | |
| 40003 | 0x03 | CT primary | 5A (CT Sec = 5A) | 10000A | 1 | Integer |
| 40003 | 0x03 | CT primary | 1A (CT Sec = 1A) | 10000A | 1 | Integer |
| 40004 | 0x04 | PT Secondary | 100V | 500V | 1 | Integer |
| 40005 | 0x05 | PT primary | 100V | 500kV | 2 | Integer |
| 40007 | 0x07 | Batt Back up | Value | Meaning | | |
| | | | 0 | No | 1 | Integer |
| | | | 1 | Yes | | |
| 40008 | 0x08 | Slave Id | 1 | 255 | 1 | Integer |
| 40009 | 0x09 | Baud rate | Value | Baud rate | | |
| | | | 0x0000 | 300 | 1 | Integer |
| | | | 0x0001 | 600 | | |
| | | | 0x0002 | 1200 | | |
| | | | 0x0003 | 2400 | | |
| | | | 0x0004 | 4800 | | |
| | | | 0x0005 | 9600 | | |
| | | | 0x0006 | 19200 | | |
| 40010 | 0x0A | Parity | Value | Parity | | |
| | | | 0x0000 | None | 1 | Integer |
| | | | 0x0001 | Odd | | |
| | | | 0x0002 | Even | | |
| 40011 | 0x0B | Stop bits | Value | Stop bit | 1 | Integer |
| | | | 0x0000 | 1 | | |
| | | | 0x0001 | 2 | | |
| | | | Value | Meaning | | |
| 40012 | 0x0C | Reset kWh | 1 | Reset Active Energy | 1 | Integer |
| 40013 | 0x0D | Reset kVAh | 1 | Reset Apparent Energy | 1 | Integer |
| 40014 | 0x0E | Reset kVAh | 1 | Reset Reactive Energy | 1 | Integer |

APPLICATION OF PULSE OUTPUT

• PROCESS INTEGRATION

Pulse output from EM368 meter can be interfaced into a process through a PLC for on line control of energy content in the process. If the PLC has a self excited 24V digital input, external 24 VDC supply is not needed. The kWh pulse is also used to derive average kWh information at the PLC.

• ENERGY CONTROLLER

Pulse output from EM368 meter can be used as alarm generator or total energy controller by interfacing it with presettable counter and control circuits (Contactors, Relay, Trip Circuit). The counter is loaded with the maximum energy consumption. When count reaches setpoint it provides output to control circuit to take appropriate action.

Order Code Information

- EM368 (Without communication version)
- EM368-C (With communication version)

(Specifications subject to change as development is a continuous process).

Selec Controls Pvt. Ltd., India
 Tel:91-22-28476443/1882, Fax:91-22-28471733,
 Toll free: 1800 227 353, Website: www.selec.com
 E- mail: sales@selec.com.