



96 x 96

**SPECIFICATIONS**

**DISPLAY**

Liquid crystal display with backlight  
3 lines, 4 digits per line to show electrical Parameters  
Dedicated 7½ digit show energy

**WIRING INPUT**

3Ø - 4 wire, 3Ø - 3 wire, 2Ø - 3 wire and  
1Ø - 2 wire system

**RATED INPUT VOLTAGE**

11 to 300V AC (L-N); 19 to 519V AC (L-L);  
Installation Category III (600V)

**UL Approval :**

11 to 277V AC (L-N); 19 to 480V AC (L-L);  
Installation Category III (600V)

**FREQUENCY RANGE**

45-65Hz

**RATED INPUT CURRENT**

Nominal 5A AC (Min-11mA, Max-6A)

**BURDEN**

0.5 VA @ 5A per phase

**CT PRIMARY**

1A / 5A to 10,000A (Programmable for any Value)  
Note : 1A to 10,000A if CT secondary is 1 else  
CT primary is 5A to 10,000A

**CT SECONDARY**

1A or 5A (programmable)

**PT PRIMARY**

100V to 10,000V (Programmable for any value)

**PT SECONDARY**

100 to 500V AC (L-L) (Programmable for any value)

**DISPLAY UPDATE TIME**

1sec. for all parameters

**DISPLAY SCROLLING**

Automatic or Manual (Programmable)

**POWER CONSUMPTION**

MFM383A / MFM383A-C : Less than 8VA  
MFM383A-24V / MFM383A-C-24V : Less than 4VA

**ENVIRONMENTAL CONDITIONS**

- Indoor use
- Altitude of up to 2000 meters
- Pollution degree II

Temperature : Operating : -10 to 55°C  
Storage : -20 to 75°C

Humidity : Up to 85% RH, non-condensing

**PROTECTION CLASS : II**

**MOUNTING**

Panel mounting

**WEIGHT**

MFM383A : 310gms ; MFM383A-C : 344gms  
MFM383A-24V : 295gms ; MFM383A-C-24V : 320gms

**OUTPUT**

**Pulse Output :** Voltage range : External 24V DC max.  
Current capacity : 100mA max.

**Pulse Width :** 100ms ±5ms.

ORDER CODE INFORMATION		
Product	Supply	Certification
MFM383A	100 to 240V AC, -15% +12%, 50 / 60Hz (±5%)	
MFM383A-CU	100 to 240V AC, -15% +12%, 50 / 60Hz (±5%)	■
MFM383A-C	100 to 240V AC, -15% +12%, 50 / 60Hz (±5%)	—
MFM383A-24V / MFM383A-C-24V	DC : 18 to 42V ; AC : 18 to 28V, 50 / 60Hz	—
<b>Installation Category II</b>		

**SERIAL COMMUNICATION [ Applicable for MFM383A-C ]**

<b>Interface standard and protocol</b>	RS485 and MODBUS RTU
<b>Communication address</b>	1 to 255
<b>Transmission mode</b>	Half duplex
<b>Data types</b>	Float and Integer
<b>Transmission distance</b>	500m maximum
<b>Transmission speed</b>	300, 600, 1200, 2400, 4800, 9600, 19200 (in bps)
<b>Parity</b>	None, Odd, Even
<b>Stop bits</b>	1 or 2
<b>Response time</b>	100 ms (max and independent of baud rate)

**ACCURACY :**

Measurement	Accuracy
Voltage $V_{L-N}$	±0.5%
Voltage $V_{L-L}$	±0.5%
Current	±0.5%
Frequency	±0.1% For L-N Voltage >20V , For L-L Voltage >35V
Active Power	1%
Apparent power	1%
Reactive Power	1%
Power factor	1%
Active energy	Class 1

**RESOLUTION :**

PT Ratio x CT Ratio	kWh	Pulse
<150	0.1K	0.1K
≥150	1K	1K

**NOTE :** 1) For Voltage, Current and Power, resolution is automatically adjusted  
2) For power factor, resolution is 0.001

**SAFETY PRECAUTIONS**

All safety related codifications, symbols and instructions that appear in this operating manual or on the equipment must be strictly followed to ensure the safety of the operating personnel as well as the instrument.

If the equipment is not used in a manner specified by the manufacturer it might impair the protection provided by the equipment.

- Do not use the equipment if there is any mechanical damage.
- Ensure that the equipment is supplied with correct voltage.

**CAUTION :**

1. Read complete instructions prior to installation and operation of the unit.
2. Risk of electric shock.
3. The equipment in its installed state must not come in close proximity to any heating sources, oils, steam, caustic vapors or other unwanted process by products.

**WIRING GUIDELINES**

**WARNING :**

1. To prevent the risk of electric shock, power supply to the equipment must be kept OFF while doing the wiring arrangement.
2. Wiring shall be done strictly according to the terminal layout. Confirm that all connections are correct.
3. Use lugged terminals.
4. To reduce electromagnetic interference use of wires with adequate ratings and twists of the same in equal size shall be made with shortest connections.
5. Layout of connecting cables shall be away from any internal EMI source.
6. Cable used for connection to power source, must have a cross section of 0.5mm<sup>2</sup> to 2.5mm<sup>2</sup> (20 to 14AWG ; 75°C (minimum)). These wires shall have current carrying capacity of 6A.
7. Copper cable should be used ( Stranded or Single core cable).
8. Before attempting work on device, ensure absence of voltages using appropriate voltage detection device.

**INSTALLATION GUIDELINES**

**CAUTION :**

1. This equipment, being built-in-type, normally becomes a part of main control panel and in such case the terminals do not remain accessible to the end user after installation and internal wiring.
2. Conductors must not come in contact with the internal circuitry of the equipment or else it may lead to a safety hazard that may in turn endanger life or cause electrical shock to the operator.
3. Circuit breaker or mains switch must be installed between power source and supply terminals to facilitate power 'ON' or 'OFF' function. However this switch or breaker must be installed in a convenient position normally accessible to the operator.
4. Before disconnecting the secondary of the external current transformer from the equipment, make sure that the current transformer is short circuited to avoid risk of electrical shock and injury.
5. The equipment shall not be installed in environmental conditions other than those mentioned in this manual.
6. The equipment does not have a built-in-type fuse. Installation of external fuse of rating 275V AC / 0.5Amp for electrical circuitry / battery is highly recommended.

**MECHANICAL INSTALLATION**

For installing the meter

1. Prepare the panel cutout with proper dimensions as shown below.
2. Push the meter into the panel cutout. Secure the meter in its place by fitting the clamp on the rear side. Fit clamps on both sides in diagonally opposite location for optimum fitting.
3. For proper sealing, tighten the screws evenly with required torque.  
Terminal screw tightening torque :  
0.68 N-m to 0.79 N-m ( 6.018 In-Lb to 6.992 In-Lb)  
Screw clamp tightening torque : 0.1N-m (0.885 Lb-inch)

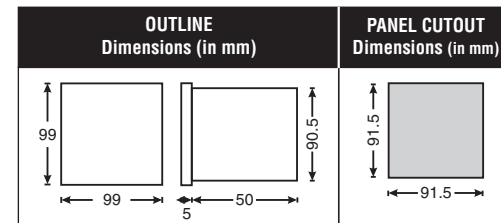

**MAINTENANCE**

1. The equipment should be cleaned regularly to avoid blockage of ventilating parts.
2. Clean the equipment with a clean dry or damp cloth. Do not use any cleaning agent other than water.

**TERMINAL CONNECTIONS**

**MFM383A / MFM383A-C**

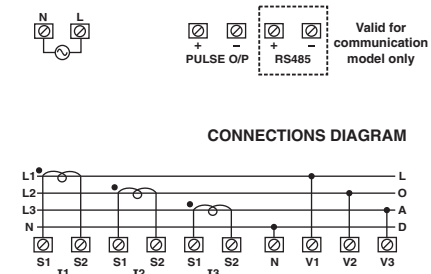

**MFM383A-24V / MFM383A-C-24V**

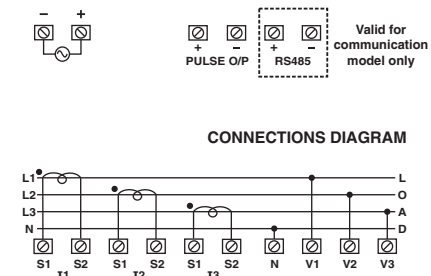

## FRONT PANEL DESCRIPTION



## ONLINE PAGE DESCRIPTION

There are 3 dedicated keys labelled as VI, VAF, P. Use these 3 keys to read meter parameters. Simply press these keys to read the parameters.

KEY PRESS	ONLINE PAGE DESCRIPTION
Press "VI"	<p><b>The 1st screen :</b> (Page 1) Displays line to neutral voltage of 3 phases.</p> <p><b>The 2nd screen :</b> (Page 2) Displays line to line voltage of 3 phases.</p> <p><b>The 3rd screen :</b> (Page 3) Displays phase current of 3 phases.</p> <p><b>Note :</b> For 3 Ø - 3 W system, only the 2nd and 3rd screen available</p>
Press "VAF"	<p><b>The 1st screen :</b> (Page 4) Displays voltage, current of 1st phase and frequency.</p> <p><b>The 2nd screen :</b> (Page 5) Displays voltage, current of 2nd phase and frequency.</p> <p><b>The 3rd screen :</b> (Page 6) Displays voltage, current of 3rd phase and frequency.</p> <p><b>The 4th screen :</b> (Page 7) Displays average value of line to neutral voltage, current of three phases and frequency.</p> <p><b>The 5th screen :</b> (Page 8) Displays average value line to line voltage, current and Power factor of three phases.</p> <p><b>Note :</b> For 3 Ø 3 W system, only the 1st, 2nd, 3rd and 5th screen available. For 3 Ø - 4 W : Display Line to Neutral Voltage For 3 Ø - 3 W : Display Line to Line Voltage</p>
Press "P"	<p><b>The 1st screen :</b> (Page 9) Displays power factor of 3 phase.</p> <p><b>The 2nd screen :</b> (Page 10) Displays active power of 3 phase.</p> <p><b>The 3rd screen :</b> (Page 11) Displays reactive power of 3 phase.</p> <p><b>The 4th screen :</b> (Page 12) Displays apparent power of 3 phase.</p> <p><b>The 5th screen :</b> (Page 13) Displays active power, reactive power and power factor of 1st phase.</p> <p><b>The 6th screen :</b> (Page 14) Displays active power, apparent power and power factor of 1st phase.</p> <p><b>The 7th screen :</b> (Page 15) Displays active power, reactive power and power factor of 2nd phase.</p>

KEY PRESS	ONLINE PAGE DESCRIPTION
Press "P"	<p><b>The 8th screen :</b> (Page 16) Displays active power, apparent power and power factor of 2nd phase.</p> <p><b>The 9th screen :</b> (Page 17) Displays active power, reactive power and power factor of 3rd phase.</p> <p><b>The 10th screen :</b> (Page 18) Displays active power, apparent power and power factor of 3rd phase.</p> <p><b>The 11th screen :</b> (Page 19) Displays total active power, reactive power and power factor of 3 phases.</p> <p><b>The 12th screen :</b> (Page 20) Displays total active power, apparent power and power factor of 3 phases.</p> <p><b>Note :</b> For 3 Ø - 3 W system only the 11th and 12th screen available.</p>

## AUTOMATIC / MANUAL MODE DESCRIPTION

Press (▼) key 3 sec. to toggle between Automatic and Manual mode.

**Note :** By default unit operates in automatic mode. In automatic mode online pages scroll automatically at the rate of 5 sec. per page. In automatic mode when any key is pressed, unit temporarily switches to manual mode and the appropriate page is displayed, also if any key is not pressed for 5sec., unit resumes automatic mode.

## SERIAL NUMBER DESCRIPTION

Press 4th key (↔) for 10sec. to display 8 digit serial number on first and second row.

## CONFIGURATION

There are 4 dedicated keys with symbols marked as ▼, ▲, ←, ↔. Use these 4 keys to enter into configuration menu / change setting.

**Note :** The settings should be done by a professional, after going through this users manual and after having understood the application situation.

For the configuration setting mode :

- Use (←) and (↔) keys for 3sec. to enter or exit from configuration menu.
- Use (▼) and (▲) keys for increasing and decreasing parameters value respectively.
- Use (←) key to go back to previous page.
- Use (↔) key to save the setting and move on next page.

Config page.	Function	Range or Selection	Factory Setting
	Password	0000 to 9998	10
1	Change Password	No / Yes	No
1.1	New Password	0000 to 9998	10
2	Network Selection	3P3W and 3P4W	3P4W
3	CT Secondary	1A or 5A	5
4	CT Primary	1A, 5A to 10,000A(10.0kA)	5
5	PT Secondary	100V to 500V	350
6	PT primary	100V to 10000V	350

Config page.	Function	Range or Selection	Factory Setting
* 7	Slave Id	1 to 255	1
* 8	Baud Rate	300, 600, 1200, 2400, 4800, 9600 and 19200	9600
* 9	Parity	None, Even, Odd	None
* 10	Stop Bit	1 or 2	1
11	Back Light	0 to 7200 sec.	0000
12	Max Page	1 to 20	20
13	Change Sequence	No / Yes	No
13.01	Page Sequence 1	1 to 20	1
13.02	Page Sequence 2	1 to 20	2
13.03	Page Sequence 3	1 to 20	3
13.04	Page Sequence 4	1 to 20	4
13.05	Page Sequence 5	1 to 20	5
13.06	Page Sequence 6	1 to 20	6
13.07	Page Sequence 7	1 to 20	7
13.08	Page Sequence 8	1 to 20	8
13.09	Page Sequence 9	1 to 20	9
13.10	Page Sequence 10	1 to 20	10
13.11	Page Sequence 11	1 to 20	11
13.12	Page Sequence 12	1 to 20	12
13.13	Page Sequence 13	1 to 20	13
13.14	Page Sequence 14	1 to 20	14
13.15	Page Sequence 15	1 to 20	15
13.16	Page Sequence 16	1 to 20	16
13.17	Page Sequence 17	1 to 20	17
13.18	Page Sequence 18	1 to 20	18
13.19	Page Sequence 19	1 to 20	19
13.20	Page Sequence 20	1 to 20	20
14	Factory Default	No / Yes	No
15	Reset Energy	No / Yes	No
* 15.1	Password	0001 to 9999	11
15.2	Reset Active Energy	No / Yes	No

\* Marked parameters are available only in MFM383A-C.

• For resetting energy parameters user will be prompted for password. If correct password is entered, the user will be able to reset all energy parameters. This password will be value which will be greater than the configuration password by 1.

NETWORK SELECTION AND WIRING INPUT	
Network selection in configuration mode	Wiring
3P4W	3P4W, 2P3W, 1P2W
3P3W	3P3W

## APPLICATION OF PULSE OUTPUT

● PROCESS INTEGRATION

Pulse output from MFM383A meter can be interfaced into a process through a PLC for on line control of energy content in the process. If the PLC has a self excited digital input, external DC supply is not needed. The kWh pulse is also used to derive average kWh information at the PLC.

● ENERGY CONTROLLER

Pulse output from MFM383A meter can be used as alarm generator or total energy controller by interfacing it with Pre-settable counter and control circuits (Contactors, Relay, Trip Circuit).

The counter is loaded with the maximum energy consumption. When count reaches setpoint it provides output to control circuit to take appropriate action.

Note : + and - is applicable only for 24V product

# All fuse types : 0.5A class CC UL type  
0.5A fast acting 600V

## MODBUS REGISTER ADDRESSES LIST

Readable parameters from MFM383A-C : [ Length (Register) : 2 ; Data Structure : Float ]

Address	Hex Address	Parameter	Address	Hex Address	Parameter
30000	0x00	Voltage V1N	30030	0x1E	kVA1
30002	0x02	Voltage V2N	30032	0x20	kVA2
30004	0x04	Voltage V3N	30034	0x22	kVA3
30006	0x06	Average Voltage LN	30036	0x24	kVAr1
30008	0x08	Voltage V12	30038	0x26	kVAr2
30010	0x0A	Voltage V23	30040	0x28	kVAr3
30012	0x0C	Voltage V31	30042	0x2A	Total kW
30014	0x0E	Average Voltage LL	30044	0x2C	Total kVA
30016	0x10	Current I1	30046	0x2E	Total kVAr
30018	0x12	Current I2	30048	0x30	PF1
30020	0x14	Current I3	30050	0x32	PF2
30022	0x16	Average Current	30052	0x34	PF3
30024	0x18	kW1	30054	0x36	Average PF
30026	0x1A	kW2	30056	0x38	Frequency
30028	0x1C	kW3	30058	0x3A	kWh

Readable / writable parameters :

Address	Hex Address	Parameter	Range		Length (Register)	Data Structure
			Min value	Max value		
40000	0x00	Password	0	9998	1	Integer
			<b>Value</b>	<b>Meaning</b>		
40001	0x01	N/W selection	0	3P-4W	1	Integer
			1	3P-3W	1	Integer
			<b>Min Value</b>	<b>Max Value</b>		
40002	0x02	CT Secondary	1	5	1	Integer
40003	0x03	CT primary (CT Secondary = 5)	5	10000	1	Integer
		CT primary (CT Secondary = 1)	1	10000		
40004	0x04	PT Secondary	100	500	1	Integer
40005	0x05	PT primary	100	10000	2	Integer
40007	0x07	Slave Id	1	255	1	Integer
			<b>Value</b>	<b>Meaning (bps)</b>		
40008	0x08	Baud rate	0x0000	300	1	Integer
			0x0001	600		
			0x0002	1200		
			0x0003	2400		
			0x0004	4800		
			0x0005	9600		
			0x0006	19200		

MODBUS register addresses list *continued*

Readable / writable parameters from MFM383A :

Address	Hex Address	Parameter	Range		Length (Register)	Data Structure
			Value	Meaning		
40009	0x09	Parity	0x0000	None	1	Integer
			0x0001	Odd		
			0x0002	Even		
40010	0x0A	Stop bit	0x0000	1	1	Integer
			0x0001	2		
40011	0x0B	Factory Default	1	Set to factory setting range	1	Integer
40012	0x0C	Reset kWh	1	Reset Total Active Energy	1	Integer
			<b>Min Value</b>	<b>Max Value</b>		
40015	0x0F	Auto Mode Pgs	1	20	1	Integer
			<b>Page No</b>	<b>Meaning</b>		
40016	0x10	Page Address Sequence	1- 20	1- First Page ; 20-Last Page	1	Integer
40017	0x11	Page Address Sequence	1- 20	1- First Page ; 20-Last Page	1	Integer
40018	0x12	Page Address Sequence	1- 20	1- First Page ; 20-Last Page	1	Integer
40019	0x13	Page Address Sequence	1- 20	1- First Page ; 20-Last Page	1	Integer
40020	0x14	Page Address Sequence	1- 20	1- First Page ; 20-Last Page	1	Integer
40021	0x15	Page Address Sequence	1- 20	1- First Page ; 20-Last Page	1	Integer
40022	0x16	Page Address Sequence	1- 20	1- First Page ; 20-Last Page	1	Integer
40023	0x17	Page Address Sequence	1- 20	1- First Page ; 20-Last Page	1	Integer
40024	0x18	Page Address Sequence	1- 20	1- First Page ; 20-Last Page	1	Integer
40025	0x19	Page Address Sequence	1- 20	1- First Page ; 20-Last Page	1	Integer
40026	0x1A	Page Address Sequence	1- 20	1- First Page ; 20-Last Page	1	Integer
40027	0x1B	Page Address Sequence	1- 20	1- First Page ; 20-Last Page	1	Integer
40028	0x1C	Page Address Sequence	1- 20	1- First Page ; 20-Last Page	1	Integer
40029	0x1D	Page Address Sequence	1- 20	1- First Page ; 20-Last Page	1	Integer
40030	0x1E	Page Address Sequence	1- 20	1- First Page ; 20-Last Page	1	Integer
40031	0x1F	Page Address Sequence	1- 20	1- First Page ; 20-Last Page	1	Integer
40032	0x20	Page Address Sequence	1- 20	1- First Page ; 20-Last Page	1	Integer
40033	0x21	Page Address Sequence	1- 20	1- First Page ; 20-Last Page	1	Integer
40034	0x22	Page Address Sequence	1- 20	1- First Page ; 20-Last Page	1	Integer
40035	0x23	Page Address Sequence	1- 20	1- First Page ; 20-Last Page	1	Integer
			<b>Min Value</b>	<b>Max Value (Sec.)</b>		
40036	0x24	Backlight	0 (Always on)	7200	1	Integer

# TYPICAL WIRING DIAGRAM

**3 PHASE 4-WIRE (COMMONLY USED)**

3 Ø - 4 WIRE, 3 CT'S

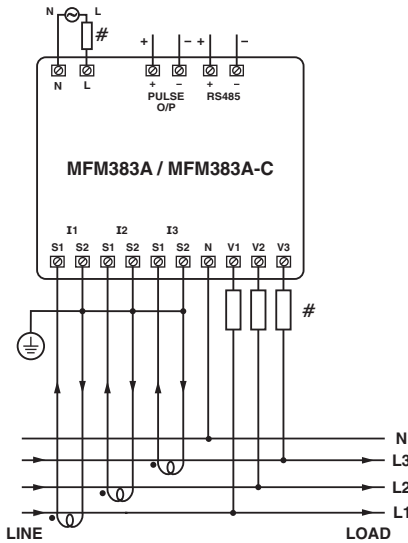

**3 PHASE 3-WIRE**

3 Ø - 3 WIRE, 2 CT'S

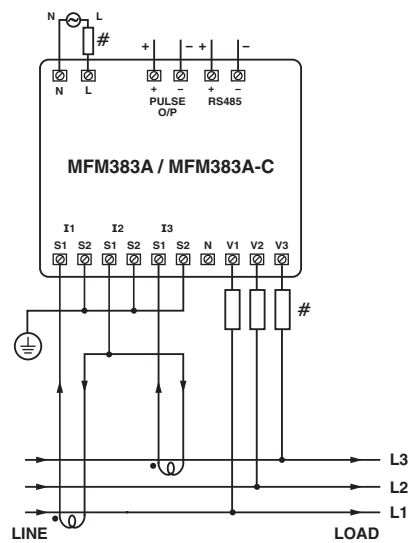

**2 PHASE - 3 WIRE**

2 Ø - 3 WIRE, 2 CT'S

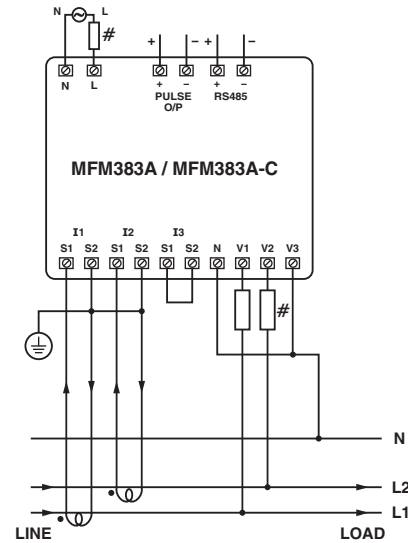

**1 PHASE - 2 WIRE**

1 Ø - 2 WIRE, 1 CT

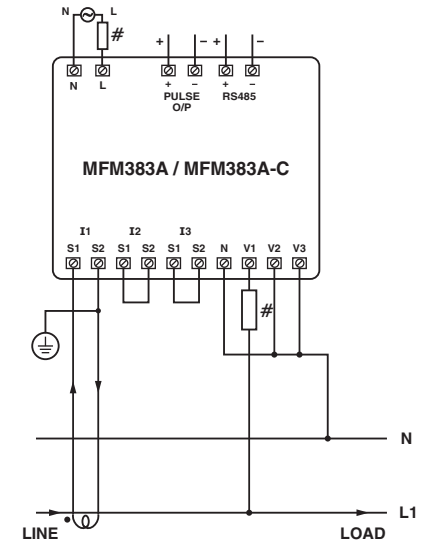

**3 Ø - 4 WIRE, 3 CT'S and 3 PT'S**

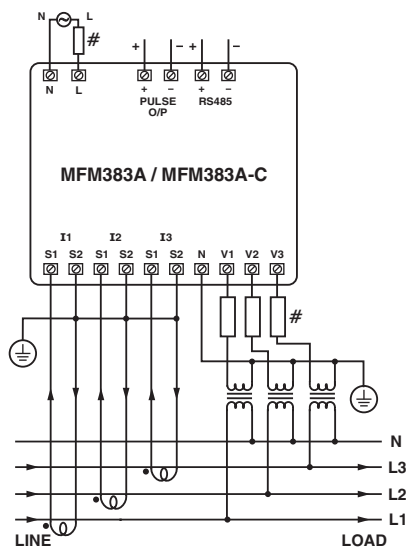

**3 Ø - 3 WIRE, 2 CT'S and 2 PT'S**

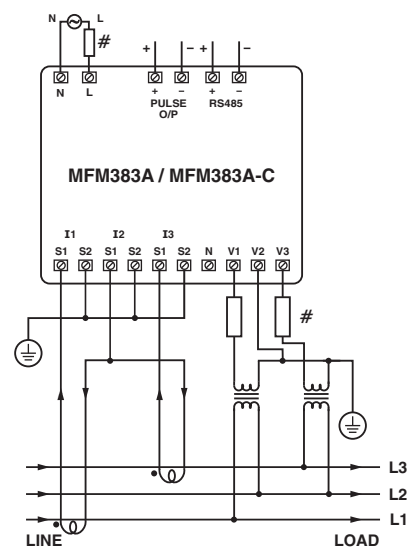

**2 Ø - 3 WIRE, 2 CT'S and 2 PT'S**

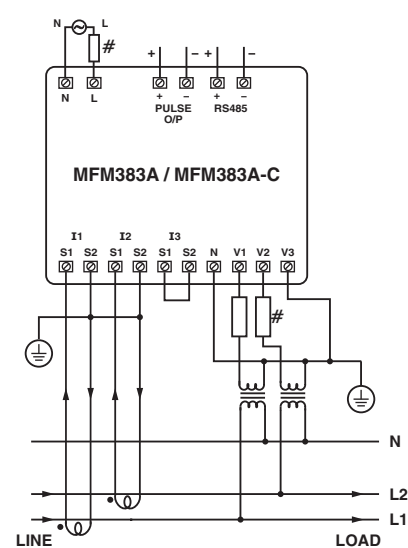

# All fuse types : 0.5A class CC UL type  
0.5A fast acting 600V

## CONNECTION DIAGRAM FOR COMMUNICATION

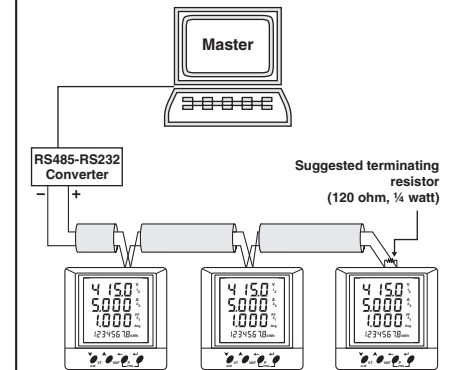

Contact sales for PC based monitoring software to communicate with the meters.

(Specifications subject to change as development is a continuous process.)

## Selec Controls Pvt. Ltd., India

Factory Address :  
EL-27/1, Electronic Zone, TTC Industrial Area,  
MIDC, Mahape, Navi Mumbai - 400 710, INDIA.  
Tel. No. : +91-22-28476443 / 1882  
Fax No. : +91-22-28471733 | Toll free : 1800 227 353  
Website: www.selec.com | Email: sales@selec.com